

ELECTRIC ROUGH TERRAIN SCISSOR LIFT

PULSEO
GENERATION

HS15 E PRO
HS18 E PRO



HIGH PERFORMANCE & ROUGH TERRAIN CAPACITIES

- > Platform capacity of 750 kg
- > Oscillating axle delivers excellent ground adherence
- > Drive axle with manual locking rear differential increases ground traction

FULL ELECTRIC DRIVE

- > Silent & clean operations
- > Versatile use: outdoor / indoor
- > Smooth & proportional movements

MAINTENANCE AND SERVICE-ORIENTED

- > Activ'Screen: on-board configuration & diagnostic interface
- > Easy access to components
- > Activ'Energy Management takes care of your battery

EXTENDED DUTY CYCLES

- > Multiple charging modes including optional accelerated charge
- > Optional & removable, low fuel consumption Range Extender (Stage 5)

HS15E PRO HS18E PRO

ELECTRIC ROUGH TERRAIN SCISSOR LIFT

TECHNICAL DATA

	HS15 E PRO	HS18 E PRO
Working height	15 m	18 m
Platform height	13 m	16 m
Max. drive working height	15 m	13 m
Lift capacity	750 kg	
Lift capacity on the extension	225 kg	
A Platform length - outside	3.82 m	
Platform length - extended	5.8 m	
Length - extension	0.93 m	
B Platform width - outside	1.89 m	
C Height - stowed	3.05 m	3.15 m
Height - guardrails lowered	2.19 m	2.29 m
D Overall width	2.3 m	
E Length	4.4 m	
F Wheelbase	2.76 m	
G Ground clearance	30.7 cm	
Drive speed	5 km/h	
Gradeability	45 %	40 %
Tilt (lonitudinal / lateral)	5° / 3°	5° / 2°
Turning radius - outside	6.75 m	
Tyres	830 x 285 mm	
Batteries	8 x 6 V - 435 Ah (C20)	
Weight	7 480 kg	8 010 kg

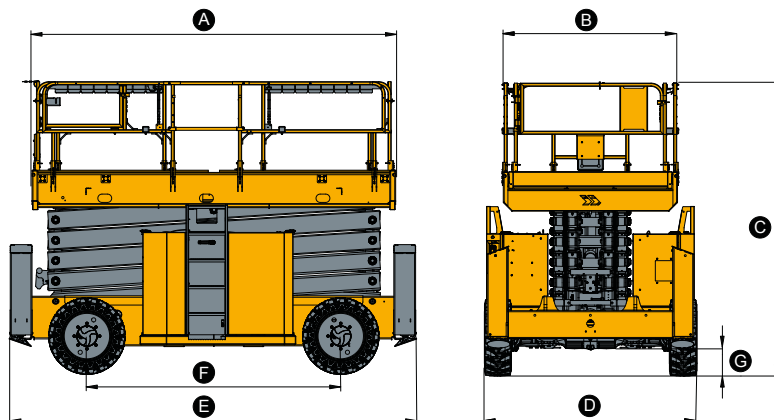

STANDARD EQUIPMENT

- > Front oscillating axle - 6°
- > 4 wheel drive
- > Mechanical axle with manual locking rear differential
- > Outriggers with centralized or individual controls
- > Dual platform extensions
- > Two drop bar entries
- > Haulotte Activ'Energy Management: smart battery management system & manual centralized watering
- > AC motors
- > 48V battery pack
- > Haulotte Activ'Screen
- > Haulotte Activ'Lighting System for safe loading in conditions of low visibility

OPTIONS AND ACCESSORIES

- > Range Extender (5.5 kW - Stage 5)
- > Cold & arctic weather kits
- > Non marking tires
- > Material handling rack
- > AC power to platform plug (110 / 230 V)
- > Double swing gate entries
- > XL platform with dual extensions (7.4 m)
- > Platform lighting
- > Work light
- > Automatic battery water-filling system
- > Accelerated charger (380 V)

